

9203mrP01

Desigo™ TRA

Room automation station PXC3.E7...

- Modular, programmable room automation stations for HVAC, lighting, and shading.
- BACnet / IP communications; BACnet profile ASC (BTL label).
- Island bus to connect TX-I/O modules with any data point mix (including bus supply).
- PL-Link peripheral bus to connect sensors, actors and room units (including bus supply).
- DALI bus to connect ballasts (including bus supply) (PXC3...A types only).
- Connection of individual KNX devices via PL-Link.
- Ethernet switch for communication and tool connection.
- USB Device interface.
- Operating voltage AC 24 V.
- Mounting on standard mounting rail.

Use

Starting with Desigo V5, PXC3 series room automation stations with Total Room Automation applications (TRA) can be used for buildings with more sophisticated requirements on functionality and flexibility. TRA is used when several disciplines (HVAC, lighting, shading) are combined to form one total solution and when total flexibility is required. TRA is perfect for solutions optimizing energy (class A) without loss of comfort.

Functions

Control of several rooms

A PXC3 series room automation station can assume control for multiple rooms.

These freely programmable room automation stations provide the infrastructure to provide and process system- and application-specific functions.

Communication

- The room automation stations have a 2-port Ethernet switch to support for low-cost cabling via line topology.
- A USB Device port is available for service and commissioning.
- TX-I/O modules connected directly to the PXC3 allow for direct connection of field devices. This offers maximum flexibility.
- The PL-Link peripheral bus supports room units, sensors, and actuating devices. Plug & play allows for connecting selected Siemens field devices to the PL-Link bus (devices with the PL-Link logo).
The PL-Link bus supports integration of commercially available KNX devices (S-Mode, requires ETS engineering).
- The DALI bus (with PXC3...A types) supports lighting control. Commercially available DALI EBGs (electronic ballasts) can be connected.

Type summary: Room automation stations

Product No. Stock No.	Function	BACnet/IP	PL-Link bus	TX-I/O modules	DALI bus
PXC3.E72 S55376-C100	typically 4 rooms typically 8 room segments *)	2 interfaces	max. 64 devices	max. 72 physical I/O points	--
PXC3.E72A S55376-C101	typically 4 rooms typically 8 room segments *)	2 interfaces	max. 64 devices	max. 72 physical I/O points	max. 64 ballasts **)
PXC3.E75 S55376-C102	typically 8 rooms typically 16 room segments *)	2 interfaces	max. 64 devices	max. 200 physical I/O points	--
PXC3.E75A S55376-C103	typically 8 rooms typically 16 room segments *)	2 interfaces	max. 64 devices	max. 200 physical I/O points	max. 64 ballasts **)

*) Architectural building grid (also called room axis)

***) Commercially available DALI -ballasts with a DALI address

Equipment combinations

PXC3 series room automation stations can be operated with **TX-I/O** and **PL-Link** devices.

DALI support: see table below.

Peripheral devices DALI (PXC3...A types only)	DALI Device Type	Supported
Fluorescent Lamps	0	Yes
Switching Function	7	Yes
Self-contained Emergency Lighting	1	No
Low Voltage Halogen Lamps	3	Partly *)
Conversion digital into D.C. Voltage	5	Partly *)
Incandescent Lamps	4	No
HID Discharge Lamps	2	No
LED Modules	6	Partly *)
Colour Control	8	No
Sequencer	9	No
Optical Control	10	No

*) Partly supported means that basic functions are supported like with type 0, but no further type specific functions.

Mechanical design

The compact build allows for mounting the devices on a standard mounting rail.

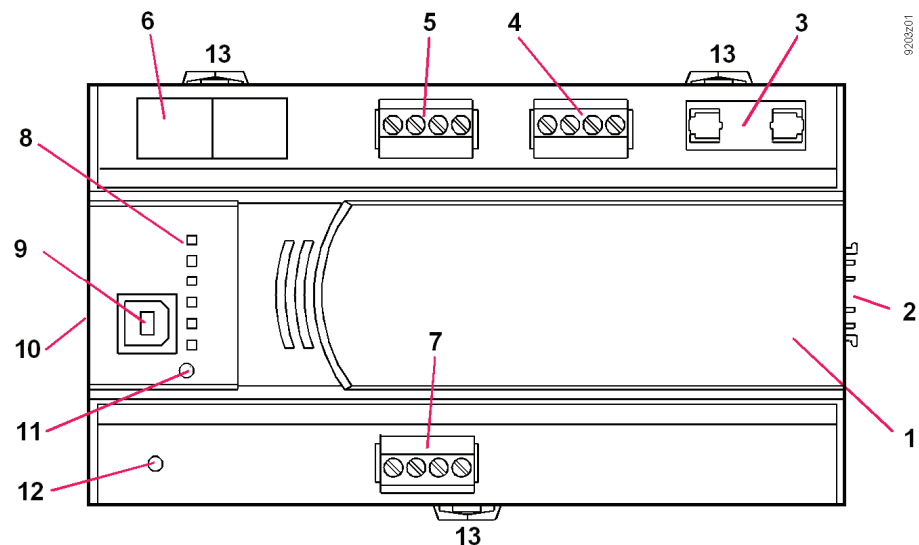

- 1 Plastic housing
- 2 Island bus plug connection
- 3 T 10 A fuse for AC 24 V peripheral supply via island bus
- 4 Plug-in terminal block (operating voltage)
- 5 Plug-in terminal block PL-Link
- 6 2-port Ethernet switch (with 2 LEDs per port for display purposes)
- 7 DALI bus (only active in PXC3...A types)
- 8 LED display for device and system status
- 9 USB Device interface
- 10 Interface for extension modules
- 11 Service pin
- 12 Service pin DALI (only in PXC3...A types)
- 13 Slider for mounting on DIN rail

Power supply

The bus supplies for island bus, PL-Link and DALI are integrated in the room automation station. They are switched off automatically as long as no device is connected to the respective bus in ABT.

For better reliability of the room automation station, the bus supplies and the AC 24 V outlets are independent from the room automations station's own supply.

PL-Link supply: The internal PL-Link supply must not be operated in parallel with an external supply. It must be switched off manually in the ABT (PI-Link rail properties) when using an external supply. This is typically the case if the devices connected to the PL-Link consume more than the 160 mA available from the internal supply. See TRA installation guide CM111043 for details.

Island bus supply: The internal bus supplies can be reinforced by external power supply modules. See TRA installation guide CM111043 for details. An additional TXS1.12F10 supply module must be switched on and off at the same time as the room automation station. Otherwise, DC 24 V island bus supply may sag, resulting in alarms.

LED indicators

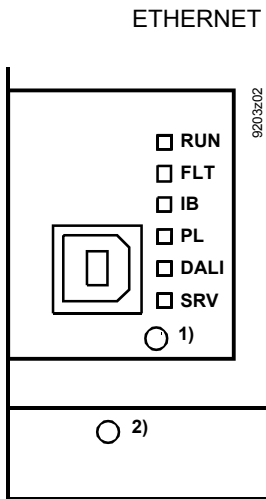

- 1) Service pin
- 2) Service pin DALI (only PXC3...A types)

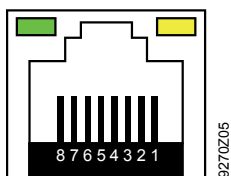

LED	Color	Activity	Function
RUN	Green	Continuously ON	Device ready to operate.
		Continuously OFF	No supply for device.
		Flashing	Start-up or program halted
FLT	Red	Continuously OFF	OK.
		Continuously ON	HW or SW error.
		Rapid flashing	Wrong or corrupted application.
IB	Yellow	Continuously ON	OK.
		Flashing	Island bus communication.
		Continuously OFF	No modules connected TX-I/O modules not configured or communication fault.
PL	Yellow	Continuously ON	OK.
		Flashing	PL-Link communication.
		Continuously OFF	PL-Link not used or communication fault.
DALI	Yellow	Continuously ON	OK (only PXC3...A types)
		Flashing	DALI bus communication (only PXC3...A types).
		Continuously OFF	DALI not used or communication fault.
SVC	Red	Continuously OFF	OK.
		Blinking	No application loaded.
		Blinking per wink command*)	Physical identification of the room automation station.
Ether-net 1 / 2	Green	Continuously ON	Link active
		Continuously OFF	Link inactive
		Flashing	Network activity
	Yellow	Continuously ON	Link 100 Mbps
		Continuously OFF	Link 10 Mbps

*) Wink command pattern:

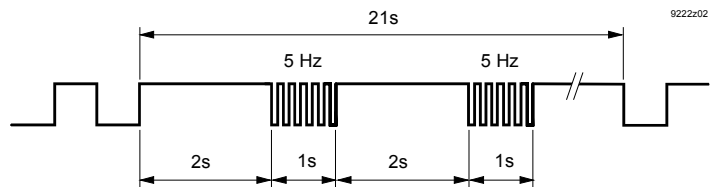

Service pins

Pin	Action	Description
1)	Short press	Physical identification of the room automation station in the network (Ethernet).
2)	Short press Long press	DALI test: All ballasts On or Off. DALI test: Start / stop the following function: "All ballasts blink (2 s On, 2 s Off)".

Product documentation

- Engineering and commissioning: See ABT online help.
- Installation: See installation manual Desigo TRA, CM111043.

Engineering

- Cable length, topology, etc.: See installation manual Desigo TRA, CM111043.
- Each device has a unique identification number for commissioning support. It is also located on the removable barcode label: See the ABT online help for the associated workflow.
- Each device has a unique serial number.

Mounting

The room automation stations can be snapped onto a standard mounting rail.

The automation station has pluggable screw terminal blocks to connect the AC 24 V supply, the AC 24 V outlets, the PL-Link, and the DALI bus.

The TX-I/O modules are snapped onto the mounting rail on the right side of the room automation station. The island bus is created automatically in this process.

Mounting position

Recommended	With restrictions *)
<ul style="list-style-type: none">• Wall, horizontal from left to right or from right to left• Wall, vertical from bottom to top.	<ul style="list-style-type: none">• Over head.• On a horizontal surface.• Wall, vertical from top to bottom.
Ambient temperature -5...50 °C	Ambient temperature -5...45 °C *)

*) 50°C is admissible if the bus supplies use max. 2/3 of the specified load: PL-Link 105mA, DALI 85mA and island bus 400mA.

Note **You must ensure, however, that sufficient ventilation is available to maintain the permissible ambient temperature for the devices (inside the cabinet / installation box). Outside, the temperature should be 10 K lower.**

Installation

See installation manual Desigo TRA, CM111043.



Note!

Island bus Polarity: If a TXS1.12F10 supply module is connected to output ↑ 24 V, do not exchange ~ and ⊥.

The devices are not damaged but island bus communication will not work.

Commissioning

In order to prevent equipment damage and/or personal injuries always follow local safety regulations and the required safety standards.

See the help file of the Setup and service assistant (SSA) for commissioning details.

Interfaces for tool access

Access for the tools to the room automation station is provided by the following interfaces on the room automation station

- Ethernet switch (BACnet/IP).
- USB Device interface (serves for FW download and generally for access to the entire LAN. For details see SSA (Setup & Service Assistant) Commissioning, CA111050).

Pause / restart of the application

The ABT supports stop / pause / resume of the application:

- HALT / RUN, e.g. to debug the code.
- STOP / RUN for a restart of the application.

Disposal



The devices are considered electronics devices for disposal in terms of European Directive 2002/96/EC (WEEE) and may not be disposed of as domestic waste.

Dispose of the devices via the proper channels.

Follow all local and currently applicable laws and regulations.

Technical data

Operating voltage (24V~, ⊥)	Safety extra-low voltage SELV or protection by extra-low voltage PELV Half-wave load	AC 24 V -15 % / +20% 48..63 Hz Symmetric
Power consumption	Max. permissible input current AC 24 V (through terminals 5 and 6) Base load (without loading by modules and field devices) Island bus supply DC 24 V / max. 600 mA PL-Link supply DC 29 V / max. 160 mA *) *) The bus supply can be switched off manually via ABT if not used. Factory setting: "Auto detection" DALI supply DC 16 V / max. 128 mA Transit power AC 24 V TX-IO: AC 24V / 6 A (island bus) PL-Link: AC 24V / 2 A (terminals 3 and 4) AC 24 V / 6 A (terminals 7 and 8, for additional AV 24 V consumers)	Total max. 10 A (Ext. fusing compulsory) 8 VA / 0.33 A 30 VA / 1.25 A 12 VA / 0.50 A 9 VA / 0.37 A 144 VA / 6 A 48 VA / 2 A 144 VA / 6 A (only if the sum of 10 A at terminals 5 and 6 is not exceeded)
Response to power / communication failure	<ul style="list-style-type: none">• Energy reserve (supercap) to support real-time clock (3 days).• Start-up time after power failure: approx. 90 s	

Fuse	AC 24 V / 2 A ↑ (PL-Link, terminals 3 and 4) AC 24 V ↑ (terminals 7 and 8) Island bus conductor V~	PTC resistor, short-circuit proof No internal fusing T 10A fuse (slow, exchangeable)
Ethernet interface	Plug Interface type Bit rate Protocol	2 x RJ45, screened 100BaseTX, IEEE 802.3 compatible 10 / 100 Mbps, autosensing BACnet over UDP/IP
USB interface	Plug Data rate (USB 1.1) Galvanic isolation of ⊥ Protective circuit against surges and over current	Type B (USB device) 12MBit/s No Yes (balancing currents are limited, also in the GND conductor)
Island bus interface DC output	Nominal voltage Max. supply Parallel switchable with 3 supply modules TXS1.12F10 Short-circuit proof, overload-proof	DC 24V 600 mA (sufficient for typically 8 TX-I/O modules) For details, see: TX-I/O planning and installation manual, CM110562) Self-resetting
Communications	Interface type Protection	Siemens specific protocol Short-circuit proof
Island bus connector on side	Protection against faulty wiring with AC 24 V	No electric protection. Use the terminal cover.
PL-Link interface	Interface type Transceiver Baud rate Bus power supply <i>Note: for devices with higher power requirement, use the output AC 24 V 2 A, see above.</i> Protection	KNX, galvanically separated TP-UART 9.6 kbps 160 mA for max 32 PL-Link devices Default: Auto detection; must be turned off via ABT if external bus supply is used. Up to 64 PL-Link devices can be operated using one or two external bus supplies. Short-circuit proof Protection against miswiring up to AC 24 V
DALI interface (only PXC3....A types)	Interface type Baud rate Insulation strength Bus power supply Protection	DALI, galvanically separated 1.2 kBit/s Reinforced insulation for 230 V (1.5 kV) Suitable for installations in overvoltage category III (4 kV). 128 mA for max 64 DALI devices Short-circuit proof Upon power-on, AC 230 V bus voltage is recognized on terminals DA+ and DA-.
		NO protection against miswiring with AC 24 V or AC 230 V: Voltage between DA+ / DA+ or between DA- / DA- will destroy the DALI PCB!
Wiring, topology, cable length	See installation manual TRA, CM111043.	

Connection terminals, plug-in	Construction type	Pluggable screw terminals
	Cu-wire or Cu-strand with wire end sleeve	1 x 0.6 mm dia. to 2.5 mm ² or 2 x 0.6 mm dia. to 1,0 mm ²
Cable lengths and wire cross sections	Cu-strand without wire end sleeve	1 x 0.6 mm dia. to 2.5 mm ² or 2 x 0.6 mmØ to 1.5 mm ²
	Screwdriver	Slot screws Screwdriver, size 1
	Max. tightening torque	0.6 Nm
Assignment as per EN 60730	See Desigo TRA installation guide, CM111043	
	Operation of automatic controller	Type 1
Housing protection standard	Degree of pollution	2
	Construction type	Protection class III
Ambient conditions	Protection type as per EN 60529	
	Front parts in the DIN section	IP30
Standards, directives and approvals	Terminal part	IP20
	Operation	As per IEC 60721-3-3
	Climatic conditions	Class 3K5
	Temperature	-5 ... 50 / 45 °C (see page 5)
	Humidity	5...95% r.h.
	Mechanical conditions	Class 3M2
	Transport	As per IEC 60721-3-2
	Climatic conditions	Class 2K3
	Temperature	-25...70 °C
	Humidity	5...95% r.h.
Environmental compatibility	Mechanical conditions	Class 2M2
	Product safety	
	Automatic electrical controls devices for household and similar use	EN 60730-1
	General requirements for Home and Building Electronic Systems (HBES) and Building Automation and Control Systems (BACS) - Part 3: Electrical safety requirements	EN 50491-3
	Electromagnetic compatibility	
	Immunity (industry & residential)	EN 60730-1
	Emissions (residential)	EN 60730-1
	General requirements for Home and Building Electronic Systems (HBES) and Building Automation and Control Systems (BACS) - Part 3: Electrical safety requirements	EN 50491-5-3
	CE conformity	
	Electromagnetic compatibility	2004/108/EU
C-tick conformity (EMC)	AS/NZS 61000-6-3.	
UL approbation	UL 916	
Environmental compatibility	eu.bac : Satisfies the requirements for eu.bac certification.	
	License numbers as per product list on:	
	http://www.eubaccert.org/licences-by-criteria.asp	
	The product environmental declaration	ISO 14001 (Environment)
	CM1E9203 contains data on environmentally compatible product design and assessments (RoHS compliance, materials composition, packaging, environmental benefit, disposal)	ISO 9001 (Quality) SN 36350 (Environmentally compatible products) 2002/95/EG (RoHS)

Color
Dimensions
Weight

Housing
Housing as per DIN 43 880, see dimensions
With / without packaging

RAL 7035 (light-gray)
373g / 349g

Connection terminals and interfaces

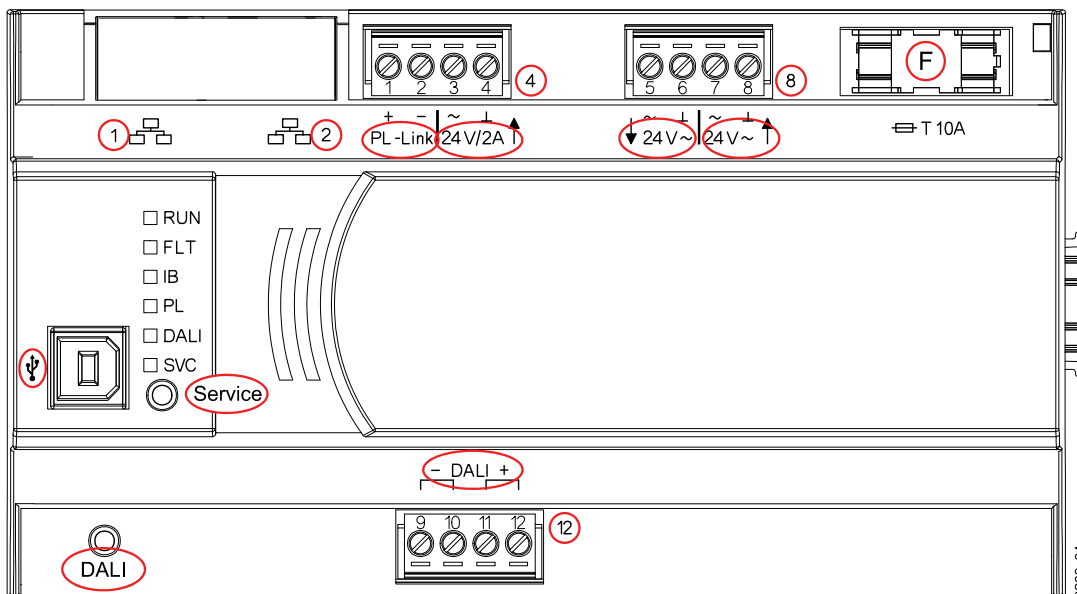

1, 2		2 x RJ45 interface for Ethernet (2-port Ethernet switch)
4 PL-Link	+ , -	PL-Link connection
4 24 V / 2A ↑	~, ⊥, 2 A	Output AC 24 V for externally supplied PL-Link devices Short-circuit proof with PTC resistor
8 ↓ 24 V~	~, ⊥	Operating voltage AC 24 V
8 24 V ↑	~, ⊥, 6 A	Output AC 24 V to supply other PXC3... room automation stations (internally connected to ↓ 24 V on pcb – no internal fusing)
F		T 10 A fuse for island bus conductor V~
	USB	USB interface
12	DALI	DALI bus connection (only for PXC3....A types)
Service		Service pin Ethernet
DALI		DALI test (only for PXC3....A types)

Basic circuit diagram (connections AC 24 V, fusing)

